

PV-L AT

Aspiratori centrifughi pale rovesce per aria molto polverosa

Backward curved blade centrifugal fans for very dusty air



DESCRIZIONE

I ventilatori della serie **PV-L AT** trovano la loro principale applicazione negli impianti industriali per il trasporto pneumatico, di fumi, o di polveri fini. Sono adatti al trasporto di materiali solidi in miscela con aria, trucioli e segatura, con ventilatore non attraversato dal materiale.

GAMMA

Diametri da 350 a 1.000 mm
Portate da 250 a 33.000 m³/h
La serie prevede esecuzioni direttamente accoppiate (esecuzione 4) e a trasmissione (esecuzione 1, 9 e 12).

TEMPERATURA DI ESERCIZIO

Temperature fino a 150°C (esecuzione 4) e 300°C (esecuzioni 1-12).

COSTRUZIONE

- Cassa a spirale realizzata in lamiera d'acciaio e protetta contro gli agenti atmosferici con vernici a polveri epossipoliestiriche.
- Bocchaglio d'aspirazione con ampio raggio realizzato in lamiera d'acciaio e protetto contro gli agenti atmosferici con vernici a polveri epossipoliestiriche.
- Girante a semplice aspirazione con pale rovesce curve ad alto rendimento aerale, realizzata in lamiera e verniciata con vernici a polveri epossipoliestiriche. Sono previste versioni per alte velocità di rotazione in classe 3.
- Per esecuzione 1 - 9 - 12: supporto monoblocco realizzato in fusione di ghisa, con cuscinetti a sfera, progettati per agevolare le operazioni di lubrificazione. Cinghie di trasmissione, pulegge e supporto motore. Carter di protezione per le cinghie.

MOTORE

Motore asincrono trifase a norme internazionali IEC 60034, IEC 60072, EMC 2014/30/UE, LVD 2014/35/UE e marcato CE IP55, classe F, idonei ad un servizio S1 (funzionamento continuo a carico costante).

ACCESSORI

- Controflangia per bocca aspirante
- Controflangia per bocca premente
- Rete di protezione per bocca aspirante
- Rete di protezione per bocca premente
- Giunto antivibrante per bocca aspirante
- Giunto antivibrante per bocca premente

DESCRIPTION

The **PV-L AT** series find their main application in industrial plants for pneumatic, smoke or fine dust conveying. They are suitable for conveying solid materials mixed with air, chips and sawdust, with the fan not passing through the material

RANGE

Diameters from 350 to 1,000 mm
Airflow from 250 to 33,000 m³/h
The series includes directly coupled (version 4) and transmission versions (versions 1, 9 and 12).

OPERATING TEMPERATURE

Temperature up to 150°C (arrangement 4) and 300°C (arrangement 1-12).

CONSTRUCTION

- Volute casing made of steel sheet and protected against atmospheric agents with epoxy paint.
- Wide radius suction nozzle made of sheet steel and protected against atmospheric agents with epoxy paint.
- Single inlet impeller with backward curved blades with high aerale efficiency, made of steel sheet and coated with epoxy paint. Versions for high-speed rotation in class 3 are available.
- For execution 1 - 9 - 12: mono-block support in cast iron with ball bearings, designed for easy lubrication. Pulleys, belts and motor support. Belt protection guard.

MOTOR

Asynchronous three-phase motors according to international standards IEC 60034, IEC 60072, EMC 2014/30/UE, LVD 2014/35/UE, CE marked, IP 55, class F, suitable to S1 service (continuous working at constant load).

ACCESSORIES

- Inlet counter-flange
- Outlet counter-flange
- Inlet protection guard
- Outlet protection guard
- Inlet flexible connector
- Outlet flexible connector

VERSIONI | VERSIONS



PV-L

Versione per temperatura aria standard da -10 a +60°C
Version for standard air temperature from -10 to +60°C



PV-L ATEX

Versione antideflagrante secondo la Direttiva 2014/34/UE
Explosion-proof version according to Directive 2014/34/UE



PV-L INOX

Versione resistente all'azione corrosiva, realizzata con cassa, bocchaglio e girante in acciaio inossidabile AISI304/316 L
Corrosion-resistant version with casing, nozzle and impeller in AISI304/316L stainless steel

CAMPO D'IMPIEGO | OPERATION FIELD

PV-L AT

Questo grafico ha il solo scopo di rappresentare le aree di funzionamento dei modelli disponibili. Per una selezione precisa utilizzare i grafici prestazionali presenti di seguito oppure contattate il nostro servizio tecnico commerciale.

This graph is only meant to represent the operating areas of the available models. For an accurate selection please use the performance graphs below or contact our technical sales department.

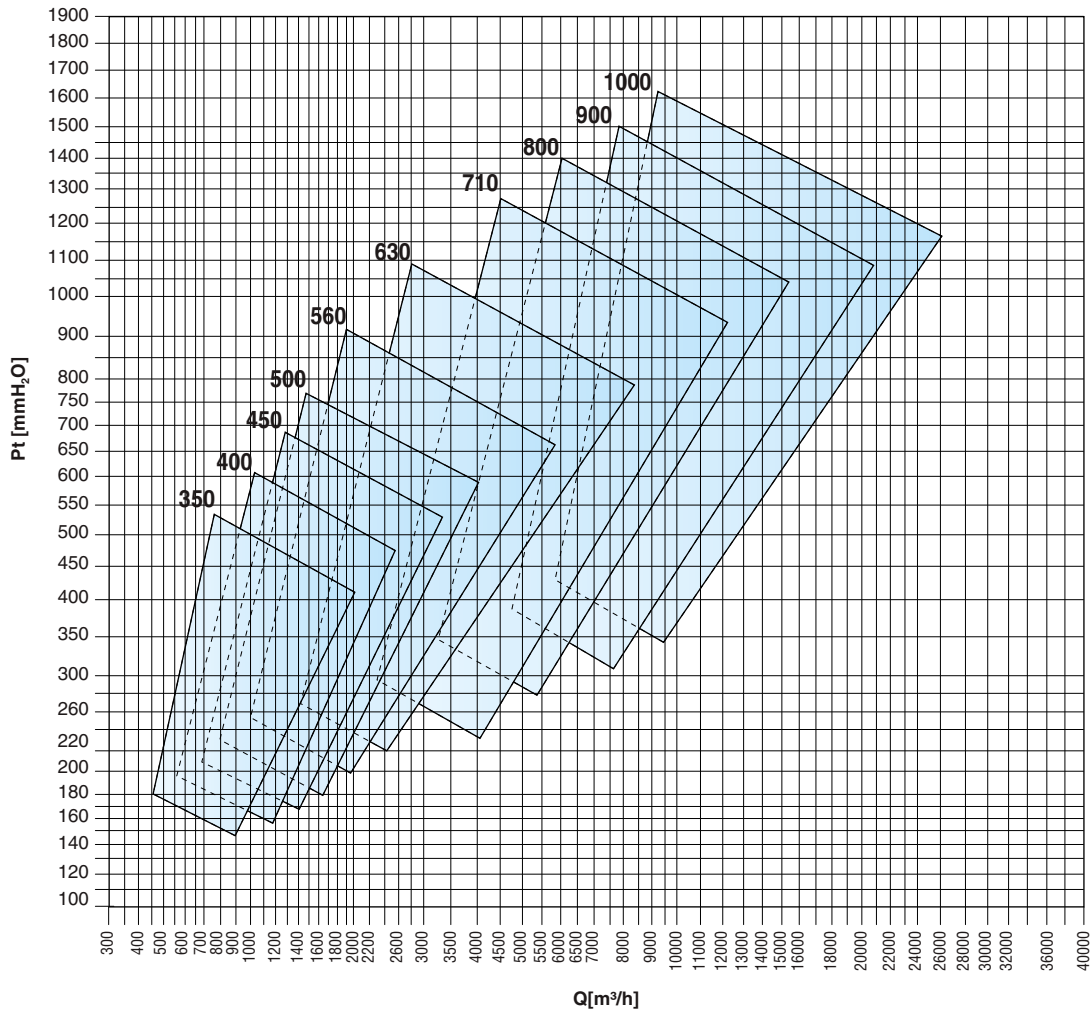

Grandezza ventilatore Fan size	RPM MAX		
	Classe I	Classe II	Classe III
PV-L AT 350 R	5000		
PV-L AT 350	5000		
PV-L AT 400 R	5000		
PV-L AT 400	5000		
PV-L AT 450 R	5000		
PV-L AT 450	5000		
PV-L AT 500 R	4750		
PV-L AT 500	4500	5000	
PV-L AT 560 R	4250	4750	
PV-L AT 560	4000	4500	
PV-L AT 630 R	3850	4150	4500
PV-L AT 630	3700	3900	4250
PV-L AT 710 R	3550	3850	4150
PV-L AT 710	3400	3700	4000
PV-L AT 800 R	3250	3550	3850
PV-L AT 800	3000	3300	3600
PV-L AT 900 R	3200	3500	3700
PV-L AT 900	3000	3250	3450
PV-L AT 1000 R	3150	3350	3450
PV-L AT 1000	3000	3150	3350

VALORI RPM VALIDI FINO A 60°C RPM VALUES VALID UP TO 60°C

Fra Between	E And	Declassare velocità Degrade speed
60°C	100°C	4%
100°C	150°C	10%
150°C	200°C	16%
200°C	250°C	23%
250°C	300°C	30%
300°C	350°C	37%
350°C	400°C	45%
400°C	450°C	54%
450°C	500°C	64%

PRESTAZIONI | PERFORMANCE

PV-L AT

Le curve prestazionali rappresentate nel presente catalogo sono state ricavate eseguendo prove sui ventilatori in accordo alla normativa ISO 5801 "Metodi di prova e condizioni di accettazione" (che sostituisce la ISO 1053:1995 ed è in accordo con la UNI EN ISO 5801:2009). Per eseguire le prove i ventilatori sono stati installati secondo quanto previsto per la categoria B: con bocca d'aspirazione libera e bocca premente collegata al banco prova. L'efficienza dei ventilatori è conforme all'obiettivo del regolamento (UE) N.327/2011, come richiesto dalla Direttiva 2009/125/CE.

The performance curves given in this catalogue were calculated by performing tests on fans in compliance with ISO 5801 "Test methods and terms of acceptance" [which replaces UNI 10531:1995 and complies with UNI EN ISO 5801:2009]. To carry out the tests the fans were installed in compliance with the requirements for category B: with free inlet and outlet connected to the test station. The fan efficiency conforms to the objective of Regulation (EU) N.327/2011, as required by Directive 2009/125/EC.

Lw La determinazione del livello di potenza sonora è stata condotta secondo la norma UNI EN ISO 3746: 1997 (Metodo di controllo con una superficie avvolgente su un piano riflettente). Alle misure sono state applicate correzioni in funzione del rumore di fondo e del riverbero ambientale. Measurement of the sound power level was carried out in compliance with UNI EN ISO 3746: 1997 (Survey method using an enveloping measurement surface over a reflecting plane). The measurements were subjected to corrections to take account of background noise and ambient reverberation levels.

PV-L AT 350

Code	Tipo Type	Modello Model	U	P	Pm (kW)	In (A)	IE3	IP/CL
A RICHIESTA UPON REQUEST	PV-L AT	352	T	2	0,75	1.90	✓	55/F
		352 A	T	2	1,10	2.30	✓	55/F

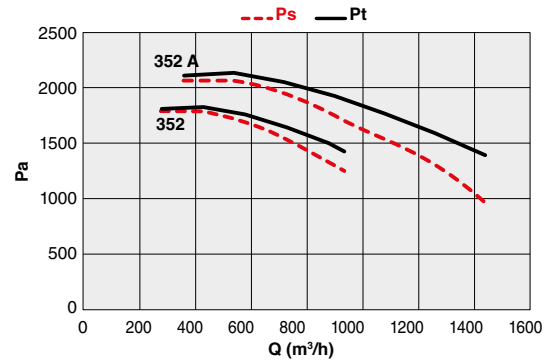

PV-L AT 400

Code	Tipo Type	Modello Model	U	P	Pm (kW)	In (A)	IE3	IP/CL
A RICHIESTA UPON REQUEST	PV-L AT	402 R	T	2	1,50	3.40	✓	55/F
		402 A	T	2	2,20	4.90	✓	55/F

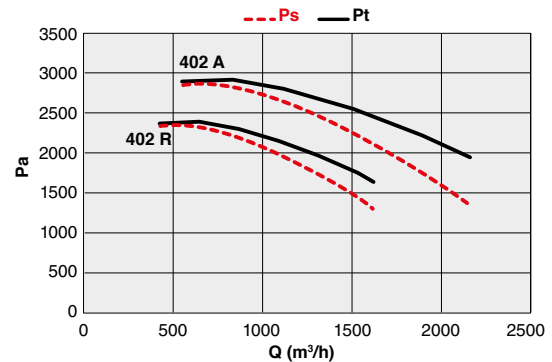

PV-L AT 450

Code	Tipo Type	Modello Model	U	P	Pm (kW)	In (A)	IE3	IP/CL
A RICHIESTA UPON REQUEST	PV-L AT	452 B	T	2	3,00	6.40	✓	55/F
		452	T	2	4,00	8.50	✓	55/F

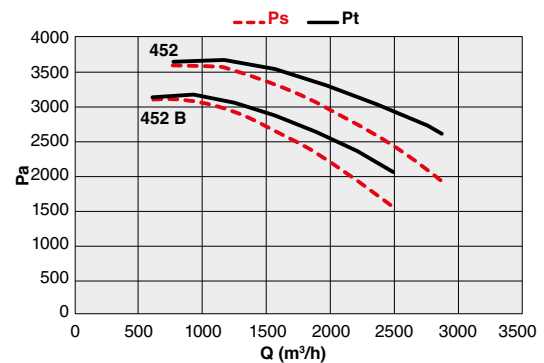

PV-L AT 500

Code	Tipo Type	Modello Model	U	P	Pm (kW)	In (A)	IE3	IP/CL
A RICHIESTA UPON REQUEST	PV-L AT	502 B	T	2	4,00	8.50	✓	55/F
		502 A	T	2	5,50	10.60	✓	55/F

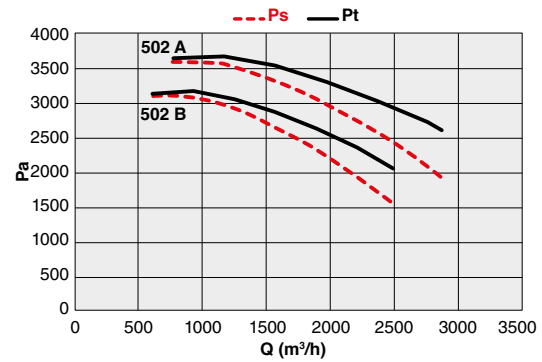

PV-L AT 560

Code	Tipo Type	Modello Model	U	P	Pm (kW)	In (A)	IE3	IP/CL
A RICHIESTA UPON REQUEST	PV-L AT	562 R	T	2	7,50	14.10	✓	55/F
		562 A	T	2	11,00	20.40	✓	55/F

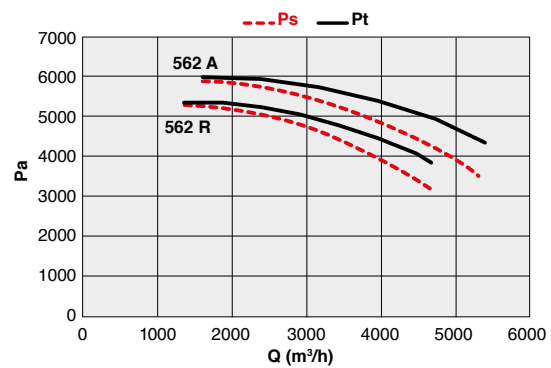

PV-L AT 630

Code	Tipo Type	Modello Model	U	P	Pm (kW)	In (A)	IE3	IP/CL
A RICHIESTA UPON REQUEST	PV-L AT	632 B	T	2	15,00	27.50	✓	55/F
		632	T	2	18,50	33.50	✓	55/F

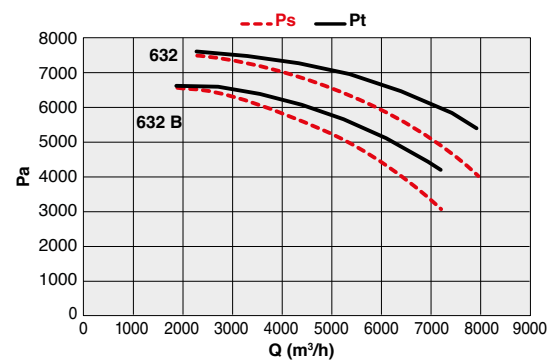

PV-L AT 710

Code	Tipo Type	Modello Model	U	P	Pm (kW)	In (A)	IE3	IP/CL
A RICHIESTA UPON REQUEST	PV-L AT	712 R	T	2	22,00	39.50	✓	55/F
		712 Br	T	2	30,00	53.50	✓	55/F
		712	T	2	37,00	65.00	✓	55/F
		714 R	T	4	4,00	8.50	✓	55/F
		714	T	4	5,50	11.30	✓	55/F

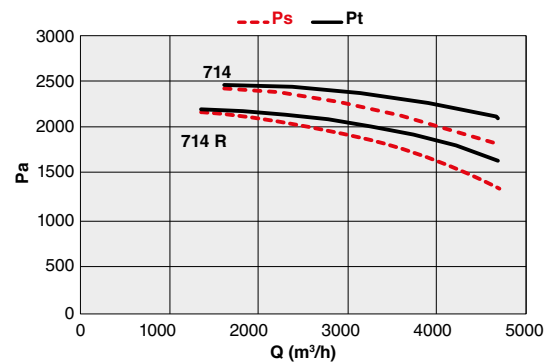
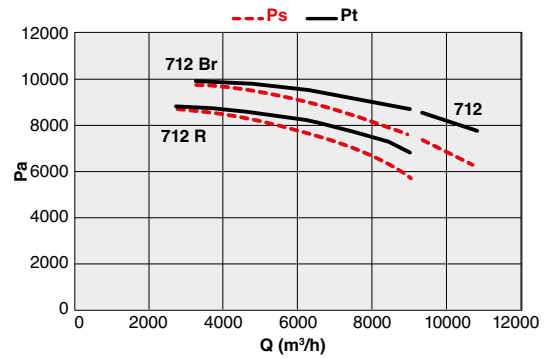

PV-L AT 800

Code	Tipo Type	Modello Model	U	P	Pm (kW)	In (A)	IE3	IP/CL
A RICHIESTA UPON REQUEST	PV-L AT	802 R	T	2	45,00	78.00	✓	55/F
		802 B	T	2	55,00	93.60	✓	55/F
		802	T	2	75,00	127.69	✓	55/F
		804 R	T	4	7,50	14.70	✓	55/F
		804	T	4	11,00	22.00	✓	55/F

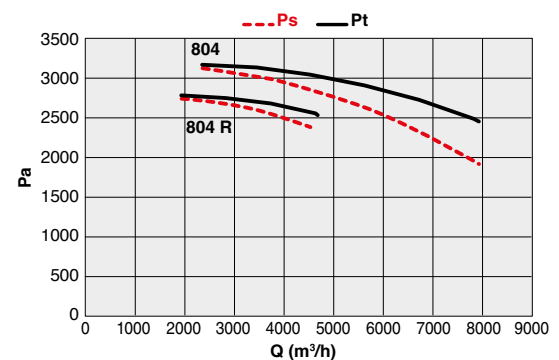
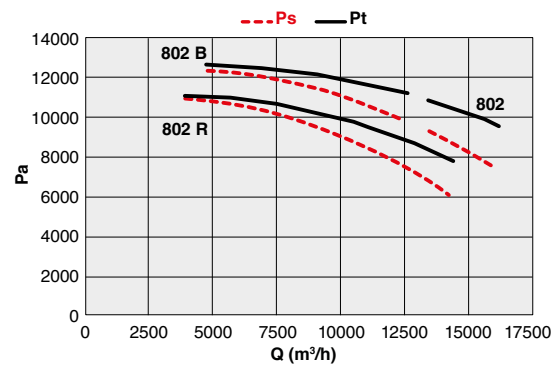

PV-L AT 900

Code	Tipo Type	Modello Model	U	P	Pm (kW)	In (A)	IE3	IP/CL
A RICHIESTA UPON REQUEST	PV-L AT	902 R	T	2	75,00	127.69	✓	55/F
		902 B	T	2	90,00	153.09	✓	55/F
		902	T	2	110,00	189.00	✓	55/F
		904 R	T	4	11,00	22.00	✓	55/F
		904	T	4	15,00	29.00	✓	55/F

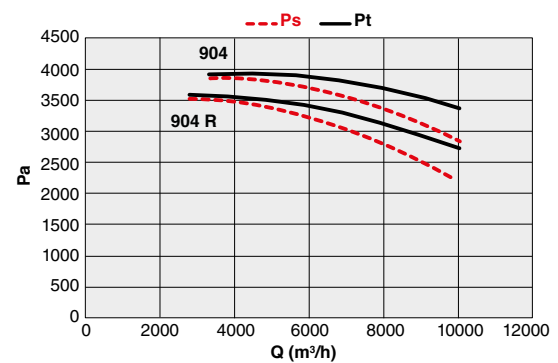
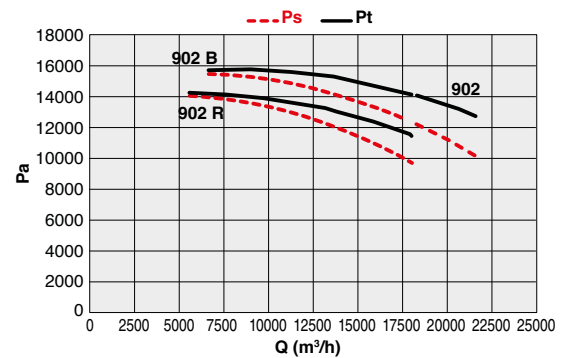

PV-L AT 1000

Code	Tipo Type	Modello Model	U	P	Pm (kW)	In (A)	IE3	IP/CL
A RICHIESTA UPON REQUEST	PV-L AT	1002 R	T	2	110,00	189.00	✓	55/F
		1002 Br	T	2	132,00	218.75	✓	55/F
		1002 B	T	2	160,00	262.63	✓	55/F
		1002	T	2	200,00	334.84	✓	55/F
		1004 R	T	4	18,50	34.90	✓	55/F
		1004	T	4	22,00	41.00	✓	55/F

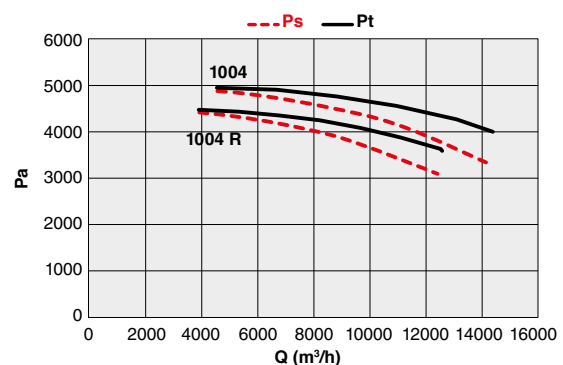
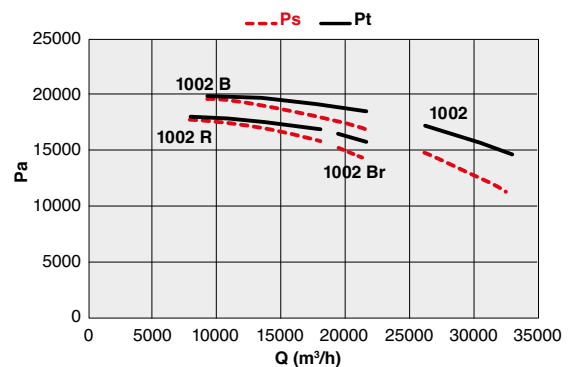

ESECUZIONE 4 ARRANGEMENT 4

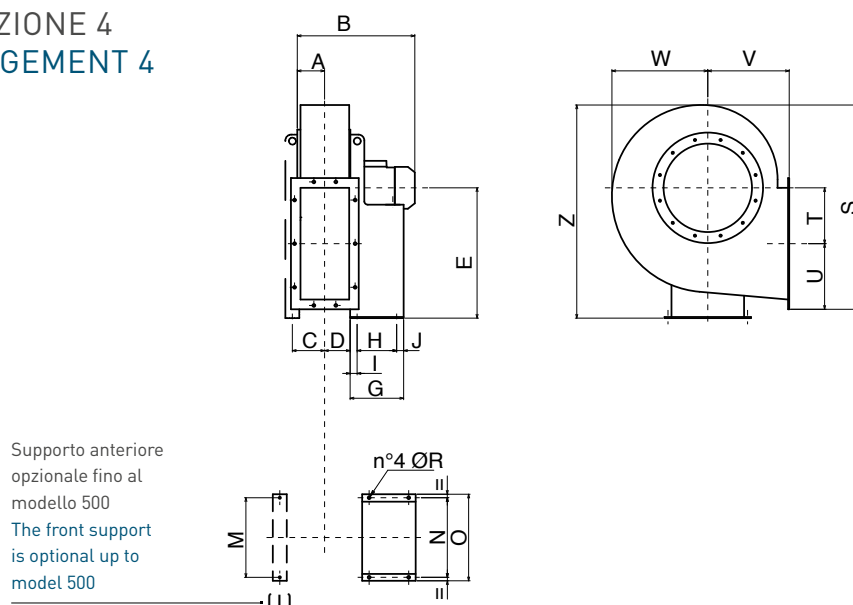

PV-L AT 350-600

TIPO TYPE	A	B	C	D	E	G	H	I	J	M	N	O	ØR	Z	S	T	U	V	W
PV-L AT 352	65	377	70	56	355	217	121	48	48	190	203	225	10	617	585	215	108	250	315
PV-L AT 352 A	65	377	70	56	355	217	121	48	48	190	203	225	10	617	585	215	108	250	315
PV-L AT 402 R	71	437	76	63	375	251	133	58	60	215	234	260	10	659	640	238	118	280	340
PV-L AT 402 A	71	437	76	63	375	251	133	58	60	215	234	260	10	659	640	238	118	280	340
PV-L AT 452 B	78	482	86	70	400	285	197	34	54	215	289	324	12	713	705	265	128	300	375
PV-L AT 452	78	482	86	70	400	285	197	34	54	215	289	324	12	713	705	265	128	300	375
PV-L AT 502 B	86	520	94	78	450	285	197	34	54	230	289	324	12	795	780	297	139	335	410
PV-L AT 502 A	86	520	94	78	450	285	197	34	54	230	337	324	12	795	780	297	139	335	410
PV-L AT 562 R	95	579	106	88	500	345	237	44	64	245	337	372	12	893	880	337	151	375	460
PV-L AT 562 A	95	579	106	88	500	345	237	44	64	245	395	372	14	893	880	337	151	375	460
PV-L AT 632 B	105	703	116	98	560	446	337	55	54	270	395	440	14	1000	985	381	164	425	515
PV-L AT 632	105	703	116	98	560	446	337	55	54	270	395	440	14	1000	985	381	164	425	515

ESECUZIONE 4 ARRANGEMENT 4

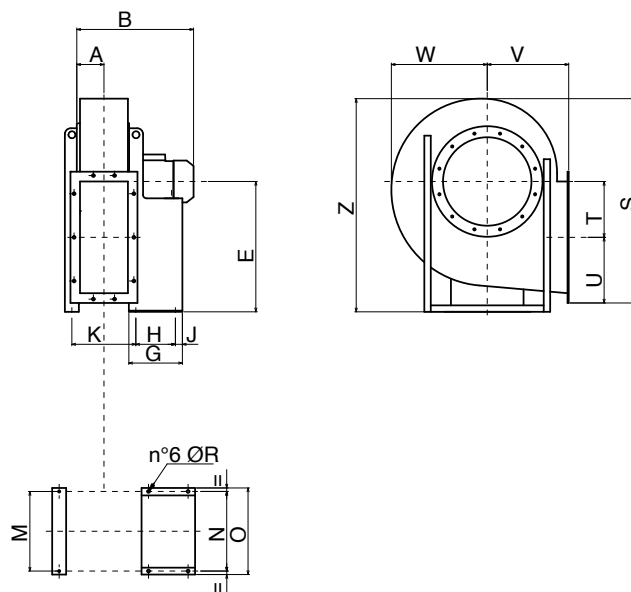

PV-L AT 700-1000

TIPO TYPE	A	B	E	G	H	J	K	N	O	ØR	M	Z	S	T	U	V	W
PV-L AT 712 R	115	809	630	460	357	33	300	434	488	17	570	1123	1103	426	184	475	570
PV-L AT 712 Br	115	917	630	500	381	39	300	506	568	19	570	1123	1103	426	184	475	570
PV-L AT 712	115	917	630	500	381	39	300	506	568	19	570	1123	1103	426	184	475	570
PV-L AT 714 R	115	583	630	285	197	54	300	289	324	12	570	1123	1103	426	184	475	570
PV-L AT 714	115	623	630	345	237	64	300	337	372	12	570	1123	1103	426	184	475	570
PV-L AT 802 R	127	984	710	540	421	39	325	556	616	19	600	1265	1237	481	201	530	640
PV-L AT 802 B	127	1092	710	600	501	39	325	604	690	19	600	1265	1237	481	201	530	640
PV-L AT 802	127	1095	710	697	591	46	325	690	750	21	600	1265	1237	481	201	530	640
PV-L AT 804 R	127	648	710	336	237	59	325	337	372	12	600	1265	1237	481	201	530	640
PV-L AT 804	127	753	710	436	337	49	325	395	440	14	600	1265	1237	481	201	530	640
PV-L AT 902 R	140	1122	800	697	591	46	354	690	750	21	663	1427	1390	542	221	600	715
PV-L AT 902 B	140	1122	800	697	591	46	354	690	750	21	663	1427	1390	542	221	600	715
PV-L AT 902	140	1334	800	800	675	45	354	760	865	24	663	1427	1390	542	221	600	715
PV-L AT 904 R	140	780	800	436	337	49	354	395	440	14	663	1427	1390	542	221	600	715
PV-L AT 904	140	780	800	436	337	49	354	395	440	14	663	1427	1390	542	221	600	715
PV-L AT 1002 R	160	1366	900	800	675	45	426	760	865	24	780	1591	1540	607	242	670	790
PV-L AT 1002 Br	160	1366	900	800	675	45	426	760	865	24	780	1591	1540	607	242	670	790
PV-L AT 1002 B	160	1366	900	800	675	45	426	760	865	24	780	1591	1540	607	242	670	790
PV-L AT 100	160	1366	900	800	675	45	426	760	865	24	780	1591	1540	607	242	670	790
PV-L AT 1004 R	160	893	900	460	357	33	426	434	488	17	780	1591	1540	607	242	670	790
PV-L AT 1004	160	944	900	460	357	33	426	434	488	17	780	1591	1540	607	242	670	790

ESECUZIONE 1 ARRANGEMENT 1

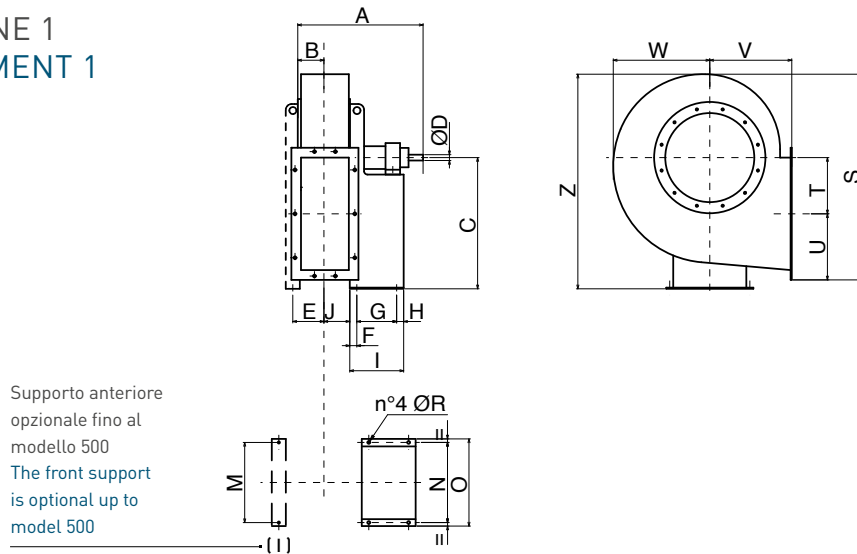

PV-L AT 310-500

TIPO TYPE	A	B	C	ØD	E	F	G	H	I	J	M	N	O	ØR	S	T	U	V	W	Z
PV-L AT 350	555	65	355	24	70	40	284	23	347	56	190	288	324	12	585	215	108	250	315	617
PV-L AT 400	720	71	375	28	76	50	407	28	485	63	215	355	400	14	640	238	118	280	340	659
PV-L AT 450	755	78	400	38	86	50	407	28	485	70	215	355	400	14	705	265	128	300	375	713
PV-L AT 500	771	86	450	38	94	50	407	28	485	78	230	355	400	14	780	297	139	335	410	795
PV-L AT 560	885	95	500	42	106	50	477	33	560	88	245	364	418	17	880	337	151	375	460	893
PV-L AT 630	905	105	560	48	116	50	477	33	560	98	270	364	418	17	985	381	164	425	515	1000

ESECUZIONE 1 ARRANGEMENT 1

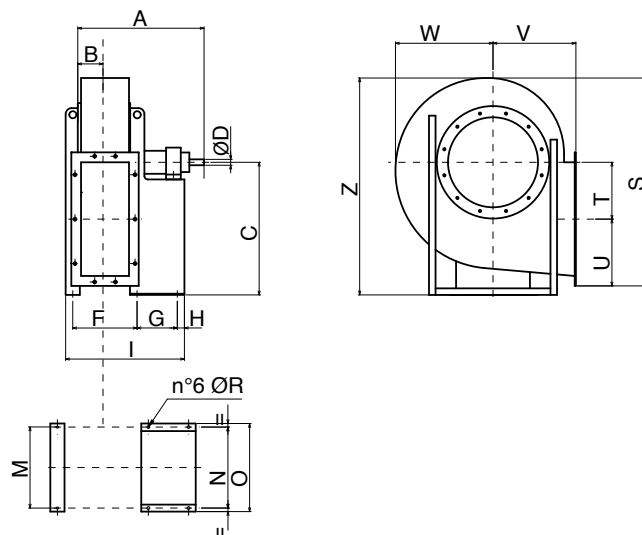

PV-L AT 560-1000

TIPO TYPE	A	B	C	ØD	F	G	H	I	M	N	O	ØR	S	T	U	V	W	Z
PV-L AT 710	1035	115	550	48	300	551	39	910	570	570	590	19	1103	426	184	475	570	1123
PV-L AT 800	1070	127	620	55	325	551	39	945	600	600	590	19	1237	481	201	530	640	1265
PV-L AT 900	1240	140	695	65	354	607	45	1051	663	663	735	19	1390	542	220,5	600	715	1428
PV-L AT 100	1435	160	770	75	426	760	45	1281	780	780	960	24	1540	607	242	670	790	1591

BOCCA ASPIRANTE | INTEL CONE

TIPO TYPE	ØR	ØS	ØT	n° F	Ø G
PV-L AT 350	185	219	250	8	8
PV-L AT 400	205	241	275	8	8
PV-L AT 450	228	265	298	8	8
PV-L AT 500	255	292	325	8	10
PV-L AT 560	285	332	365	8	12
PV-L AT 630	320	366	400	8	12
PV-L AT 710	360	405	440	8	12
PV-L AT 800	405	448	485	12	12
PV-L AT 900	455	497	535	12	12
PV-L AT 1000	505	551	585	12	14

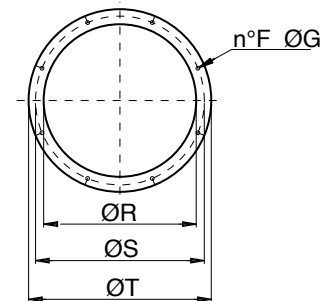

BOCCA PREMENTE | OUTLET CONE

TIPO TYPE	A	B	a1	b1	a2	b2	N1 x p	N2 x p	n° D	Ø E
PV-L AT 350	146	105	182	139	216	175	-	1 x 112	6	12
PV-L AT 400	166	117	200	151	236	187	-	1 x 112	6	12
PV-L AT 450	185	131	219	165	255	201	-	1 x 112	6	12
PV-L AT 500	207	148	241	182	277	218	1 x 112	1 x 112	8	12
PV-L AT 560	231	166	265	200	301	236	1 x 112	1 x 112	8	12
PV-L AT 630	258	185	292	219	328	255	1 x 112	2 x 112	10	12
PV-L AT 710	288	205	332	249	368	285	1 x 125	2 x 125	10	12
PV-L AT 800	322	229	366	273	402	309	1 x 125	2 x 125	10	12
PV-L AT 900	361	256	405	300	441	336	1 x 125	2 x 125	10	12
PV-L AT 1000	404	288	448	332	484	368	2 x 125	3 x 125	14	12

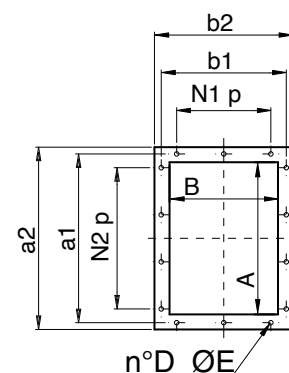

DIMENSIONI E ORIENTAMENTI mm

PV-L AT

DIMENSIONS AND DISCHARGE ANGLES

Dimensioni dei modelli secondo l'orientamento.

Dimensions of models according to the discharge angle.

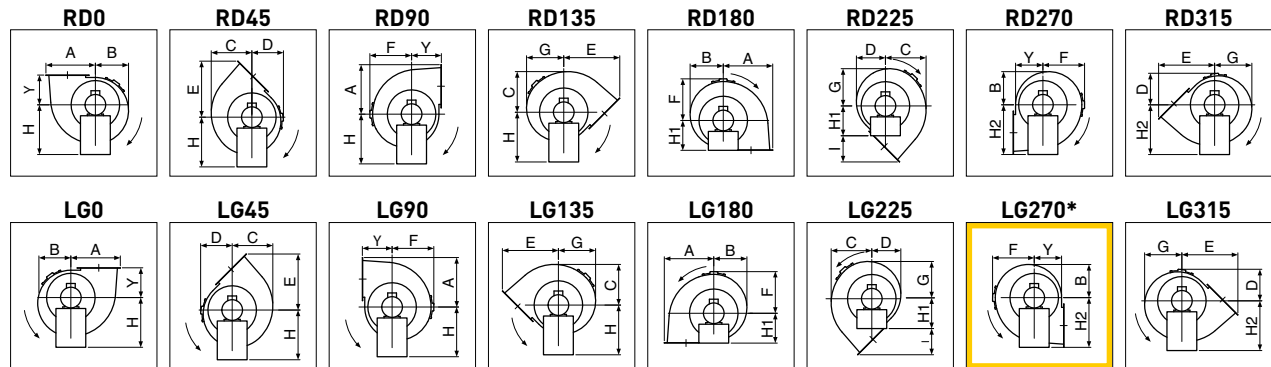

* Versione standard | Standard version.

TIPO TYPE	A	B	C	D	E	F	G	I	Y	H	H1	H2
PV-L AT 350	323	262	287	272	405	315	280	155	250	355	250	355
PV-L AT 400	356	284	314	293	450	340	302	170	280	375	280	375
PV-L AT 450	393	313	350	319	490	375	335	190	300	400	300	400
PV-L AT 500	436	345	386	350	546	410	370	211	335	450	335	450
PV-L AT 560	488	393	438	392	613	460	418	238	375	500	375	500
PV-L AT 630	545	440	493	438	688	515	472	263	425	560	425	560
PV-L AT 710	610	493	547	489	767	570	522	292	475	630	475	630
PV-L AT 800	682	555	622	545	854	640	592	324	530	710	530	710
PV-L AT 900	762,5	627,5	696	617	963	715	668	363	600	800	600	800
PV-L AT 1000	849	691	805	640	1074	790	765	404	670	900	670	900

PESI | WEIGHTS

Modello Model	Kg*
PV-L AT 352	35
PV-L AT 352 A	36
PV-L AT 402 R	46
PV-L AT 402 A	50
PV-L AT 452 B	60
PV-L AT 452	80
PV-L AT 502 B	92
PV-L AT 502 A	107
PV-L AT 562 R	122
PV-L AT 562 A	163
PV-L AT 632 B	175

Modello Model	Kg*
PV-L AT 632	193
PV-L AT 712 R	300
PV-L AT 712 Br	390
PV-L AT 712	390
PV-L AT 714 R	194
PV-L AT 714	211
PV-L AT 802 R	526
PV-L AT 802 B	664
PV-L AT 802	794
PV-L AT 804 R	255
PV-L AT 804	286

Modello Model	Kg*
PV-L AT 902 R	926
PV-L AT 902 B	969
PV-L AT 902	1109
PV-L AT 904 R	380
PV-L AT 904	401
PV-L AT 1002 R	1240
PV-L AT 1002 Br	1400
PV-L AT 1002 B	1460
PV-L AT 100	1660
PV-L AT 1004 R	620
PV-L AT 1004	640

* Pesi indicativi / Indicative weights



LATO ASPIRANTE | INLET SIDE

Flangia - Rete - Giunto | Flange - Guard - Flexible connector

FLANGIA | FLANGE

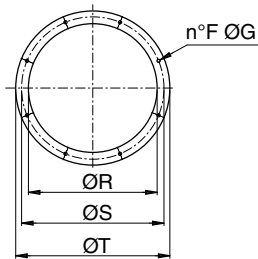

RETE | GUARD

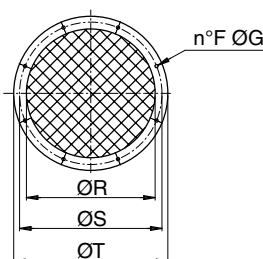

GIUNTO | FLEXIBLE CONNECTOR

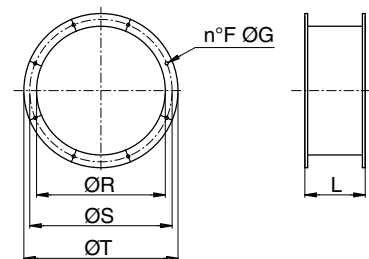

Flangia Flange	Rete Guard	Giunto Connector	Tipo Type	ØR	ØS	ØT	F	ØG	L
5B01325	5RE1021	5SU3142	350	185	219	250	8	8	145
5B01328	5RE1017	5SU1405	400	205	241	275	8	8	145
5B01327	5RE1018	5SU3137	450	228	265	298	8	8	145
5B01323	5RE4050	5SU1096	500	255	292	325	8	10	145
5B01364	5RE1027	5SU3147	560	285	332	365	8	12	145
5B01334	5RE1002	5SU3101	630	320	366	400	8	12	145
5B01330	5RE1022	5SU3500	710	360	405	440	8	12	145
5B01347	5RE5606	5SU4022	800	405	448	485	12	12	145
5B08105	5RE1046	5SU4024	900	455	497	535	12	12	145
5B01380	5RE1180	5SU5003	1000	505	551	585	12	14	180

Dimensioni in mm | Dimensions in mm

LATO PREMENTE | OUTLET SIDE

Flangia - Rete - Giunto | Flange - Guard - Flexible connector

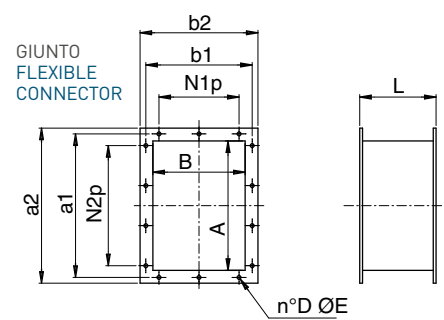
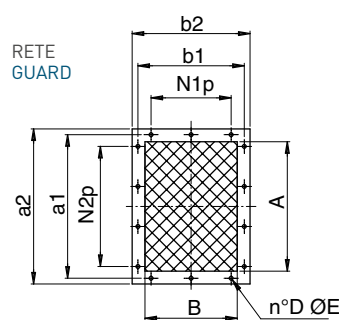
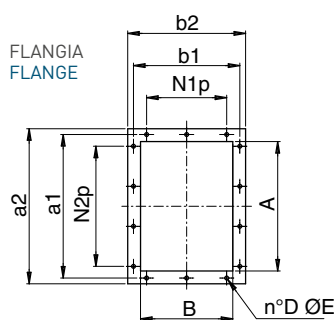

Flangia Flange	Rete Guard	Giunto Connector	Tipo Type	A	B	a1	b1	a2	b2	N1 x p	N2 x p	n° D	Ø E	L
5B08108	5RE3018	5SU1410	350	146	105	182	139	216	175	-	1 x 112	6	12	145
5B01332	5RE1007	5SU1411	400	166	117	200	151	236	187	-	1 x 112	6	12	145
5B04505	5RE4505	5SU1017	450	185	131	219	165	255	201	-	1 x 112	6	12	145
5B05019	5RE4051	5SU3018	500	207	148	241	182	277	218	1 x 112	1 x 112	8	12	145
5B01329	5RE1019	5SU1019	560	231	166	265	200	301	236	1 x 112	1 x 112	8	12	145
5B01324	5RE3138	5SU9004	630	258	185	292	219	328	255	1 x 112	2 x 112	10	12	145
5B01365	5RE1130	5SU3143	710	288	205	332	249	368	285	1 x 125	2 x 125	10	12	145
5B01362	5RE1348	5SU1131	800	322	229	366	273	402	309	1 x 125	2 x 125	10	12	145
5B01340	5RE1023	5SU3138	900	361	256	405	300	441	336	1 x 125	2 x 125	10	12	145
5B01344	5RE1020	5SU1130	1000	404	288	448	332	484	368	2 x 125	3 x 125	14	12	145

Dimensioni in mm | Dimensions in mm