



CCB

Aspiratori assiali intubati biforcati Bifourcated duct axial fans



DESCRIZIONE

La serie CCB è destinata ad impianti per l'estrazione di fumi caldi, atmosfere umide e sature di grasso o polvere, in cui il motore deve essere completamente isolato dal fluido convogliato. Sono utilizzati ad esempio per l'estrazione d'aria da cucine, cabine di verniciatura, forni, fonderie...

L'installazione e la manutenzione sono facilitate grazie al montaggio "in linea" con il canale. Gli apparecchi della serie CCB sono progettati per il funzionamento con aria con temperatura superiore a +100°C fino a +200°C in servizio continuo.

COSTRUZIONE

- Cassa in acciaio inox AISI 304, con cassetta portamotore stagna, con flangia di fissaggio realizzata a norma ISO 13351.
- Girante con pale a profilo alare in alluminio e mozzo in fusione di lega d'alluminio, ad alta efficienza, bilanciata secondo ISO 1940. Angolo di calettamento variabile da fermo.
- Esecuzione 4 (accoppiamento diretto con girante a sbalzo) e flusso aria da girante a motore.

MOTORE

Motore asincrono trifase o monofase a norme internazionali IEC 60034, IEC 60072, EMC 2004/30/UE, LVD 2014/35/UE e marcato CE IP55, classe F. Servizio S1 (funzionamento continuo a carico costante).

ACCESSORI

CCr - Rete di protezione piana
CCga - Giunto antivibrante
CCst - Staffe di fissaggio
CCbo - Boccaglio in aspirazione
CCsa e CCsb - Silenzianti con e senza ogiva con tre diverse lunghezze
CCf - Controflange
CCfc - Controflange con collare
Supporti antivibranti.

DESCRIPTION

The bifurcated CCB fans are designed for conveying hot smoke, fumes and vapours, fluids with high humidity and/or saturated by grease, oil or particles, where the motor has to be totally out of the air flow. For example, they are used in professional kitchens, painting booths, furnaces, foundries, cooling/evaporative tower, etc.

Distinguished by easy installation and maintenance. The casing is double ended with standard flanges, allowing its installation either along the ducting or at both ends. The fans of the CCB series are designed for conveying air with a temperature higher than +100°C and up to +200°C in continuous service.

CONSTRUCTION

- Stainless steel AISI 304 casing, with airtight motor housing, with fixing flanges manufactured according to ISO 13351.
- High performance axial impeller with aerofoil profile blades and hub in die-cast aluminium, balanced according to ISO 1940. Variable pitch angle.
- Execution 4 (with impeller directly coupled to motor with feet) and airflow from impeller to motor.

MOTOR

Asynchronous three-phase or single-phase motors according to international standards IEC 60034, IEC 60072, EMC 2014/30/UE, LVD 2014/35/UE, CE marked, IP 55, class F. Suitable to S1 service (continuous working at constant load).

ACCESSORIES

CCr - Flat protection guard
CCga - Flexible connectors
CCst - Support feet
CCbo - Inlet/outlet bell mouth
CCsa and CCsb - Silencers, with and without pod, in three lengths
CCf - Counter flange
CCfc - Counter flange with collar
Anti-vibration mounts.

A RICHIESTA UPON REQUEST

- Cassa in lamiera d'acciaio verniciata a polveri epossidiche.
- Casing in steel sheet with epoxy paint

sez.
1.11

CCB aspiratori fans

PRESTAZIONI | PERFORMANCE

CCB

Le prestazioni aerauliche sono rilevate in conformità alla norma EN ISO 5801/AMCA 210 con densità dell'aria standard avente peso specifico 1,2 kg/m³.
Alimentazione 230V/1Ph/50Hz o 400V/3Ph/50Hz.

Air performances measured according to EN ISO 5801 / AMCA 210 standard with air density with 1.2 kg/m³ specific weight.
Power supply 230V/1Ph/50Hz or 400V/3Ph/50Hz.

Lp Livello di pressione sonora rilevato in condizioni di campo libero, propagazione emisferica, categoria di misura C a norma EN ISO 13349, nel punto di massimo rendimento, alla distanza di 3 metri dal lato aspirazione e si presenta solo per fini comparativi.

Sound pressure level measured in free field conditions, propagation hemispherical, measurement category C in accordance with EN ISO 13349, at the point of maximum efficiency, at a distance of 3 meters (for comparative purposes only).

Lw Livello di potenza sonora ottenuto secondo norma ISO 3746. Tolleranza +/- 3 dB(A).

Sound power level obtained in accordance with EN ISO 3746. Tolerance +/- 3 dB(A).

CCB 500 - 2 poli

Code	Tipo Type	Modello Model	U	P	Pm (kW)	In (A)	IP/CL	IE3	Mot. (Gr)
1CC5342		502-A	T	2	4,00	7,40	55/F	✓	100
1CC5343	CCB	502-B	T	2	3,00	5,80	55/F	✓	100
1CC5344		502-C	T	2	2,20	4,30	55/F	✓	90

LIVELLI SONORI | SOUND LEVELS dB(A)

Hz		63	125	250	500	1000	2000	4000	8000	TOT
502A	Lw	55	66	75	87	81	79	76	71	89
	Lp	37	48	57	69	63	61	58	53	71
502B	Lw	54	65	74	86	80	78	75	70	88
	Lp	36	47	56	68	62	60	57	52	70
502C	Lw	51	62	72	83	77	75	72	67	85
	Lp	33	44	54	65	59	57	54	49	68

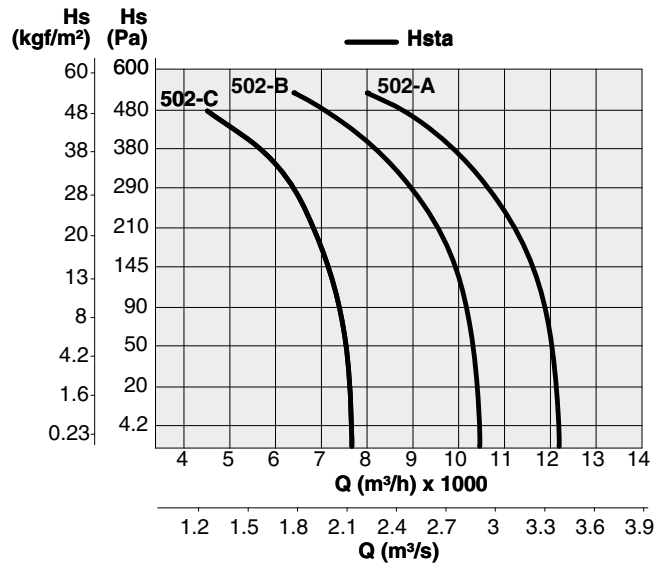

CCB 500 - 4 poli

Code	Tipo Type	Modello Model	U	P	Pm (kW)	In (A)	IP/CL	IE3	Mot. (Gr)
1CC5345		504-A	T	4	0,75	2,10	55/F	✓	80
1CC5346	CCB	504-B	T	4	0,55	1,60	55/F	-	80

LIVELLI SONORI | SOUND LEVELS dB(A)

Hz		63	125	250	500	1000	2000	4000	8000	TOT
504A	Lw	42	53	69	67	68	66	63	58	74
	Lp	24	35	51	49	50	48	45	40	57
504B	Lw	40	51	67	65	66	64	61	56	72
	Lp	22	33	49	47	48	46	43	38	55

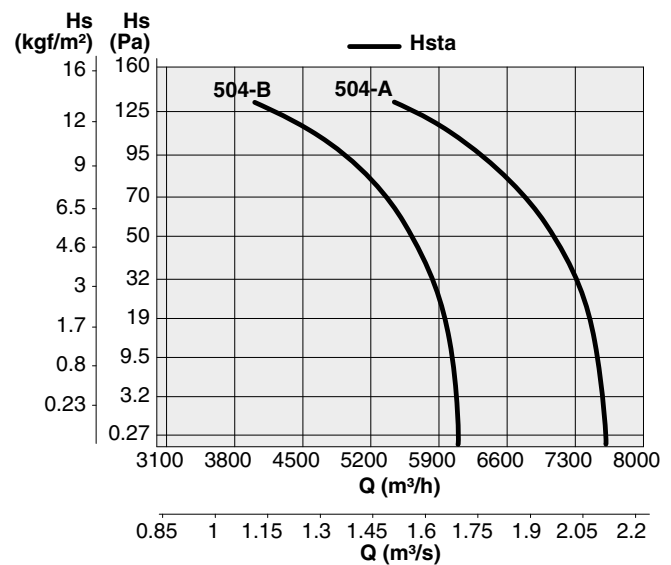

SBZ
1.11

CCB aspiratori | fans

CCB 560 - 2 poli

Code	Tipo Type	Modello Model	U	P	Pm (kW)	In (A)	IP/CL	IE3	Mot. (Gr)
1CC5611	CCB	562-A	T	2	9,20	16,60	55/F	✓	132
1CC5612		562-B	T	2	7,50	13,30	55/F	✓	132
1CC5613		562-C	T	2	4,00	7,40	55/F	✓	112

LIVELLI SONORI | SOUND LEVELS dB(A)

Hz		63	125	250	500	1000	2000	4000	8000	TOT
562A	Lw	57	68	78	89	83	81	78	73	91
	Lp	39	50	60	71	65	63	60	55	74
562B	Lw	55	66	76	87	81	79	76	71	89
	Lp	37	48	58	69	63	61	58	53	72
562C	Lw	53	64	73	85	79	77	74	69	87
	Lp	35	46	55	67	61	59	56	51	69

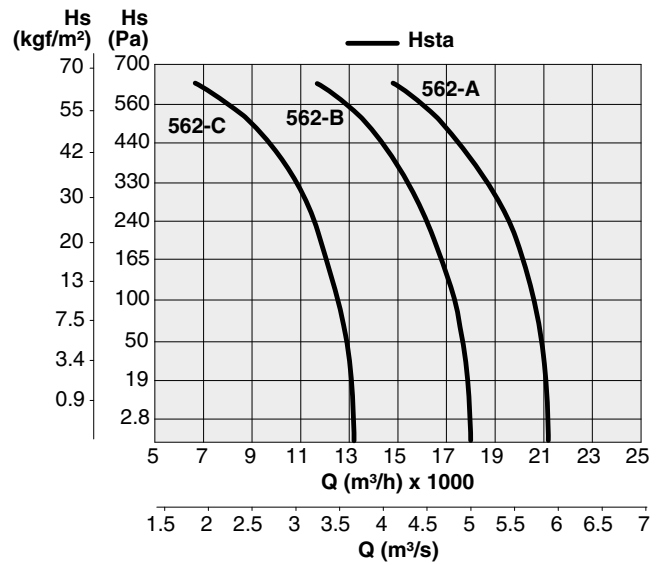

CCB 560 - 4 poli

Code	Tipo Type	Modello Model	U	P	Pm (kW)	In (A)	IP/CL	IE3	Mot. (Gr)
1CC5614	CCB	564-A	T	4	1,50	3,30	55/F	✓	90
1CC5615		564-B	T	4	1,10	2,50	55/F	✓	90

LIVELLI SONORI | SOUND LEVELS dB(A)

Hz		63	125	250	500	1000	2000	4000	8000	TOT
564A	Lw	44	55	71	69	70	68	65	60	76
	Lp	26	37	53	51	52	50	47	42	59
564B	Lw	40	51	68	65	66	64	61	56	72
	Lp	22	33	50	47	48	46	43	38	55

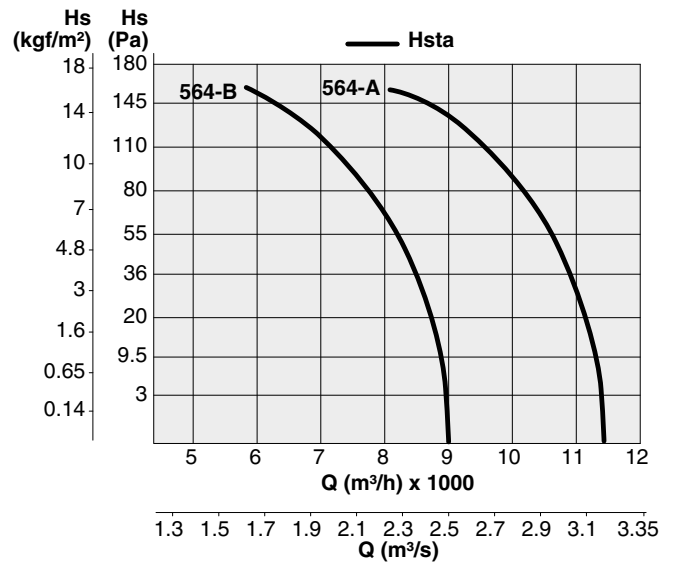

CCB 630 - 2 poli

Code	Tipo Type	Modello Model	U	P	Pm (kW)	In (A)	IP/CL	IE3	Mot. (Gr)
1CC6324		632-A	T	2	9,20	16,60	55/F	✓	132
1CC6325	CCB	632-B	T	2	7,50	13,30	55/F	✓	132
1CC6326		632-C	T	2	5,50	10,00	55/F	✓	132

LIVELLI SONORI | SOUND LEVELS dB(A)

Hz		63	125	250	500	1000	2000	4000	8000	TOT
632A	Lw	59	70	80	91	85	83	80	75	93
	Lp	41	52	62	73	67	65	62	57	76
632B	Lw	58	69	78	90	84	82	79	74	92
	Lp	40	51	60	72	66	64	61	56	74
632C	Lw	57	68	77	89	83	81	78	73	91
	Lp	39	50	59	71	65	63	60	55	73

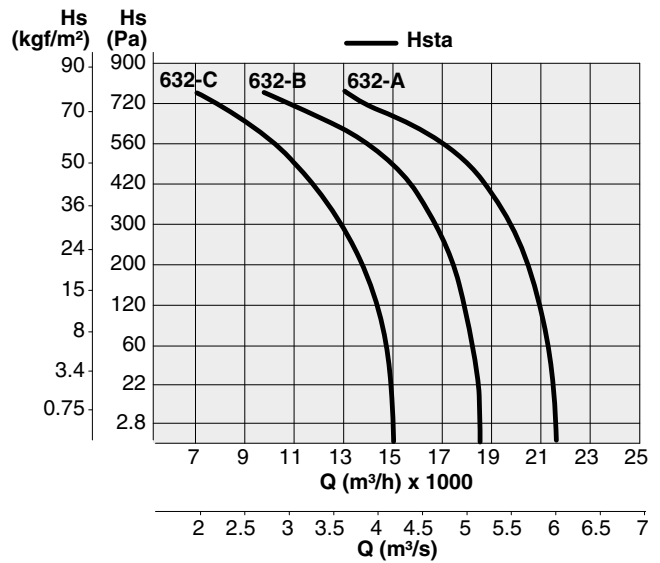

CCB 630 - 4 poli

Code	Tipo Type	Modello Model	U	P	Pm (kW)	In (A)	IP/CL	IE3	Mot. (Gr)
1CC6327		634-A	T	4	3,00	6,30	55/F	✓	100
1CC6328	CCB	634-B	T	4	2,20	4,60	55/F	✓	100

LIVELLI SONORI | SOUND LEVELS dB(A)

Hz		63	125	250	500	1000	2000	4000	8000	TOT
634A	Lw	49	60	76	74	75	73	70	65	81
	Lp	31	42	58	56	57	55	52	47	64
634B	Lw	46	57	74	71	72	70	67	62	78
	Lp	28	39	56	53	54	52	49	44	61

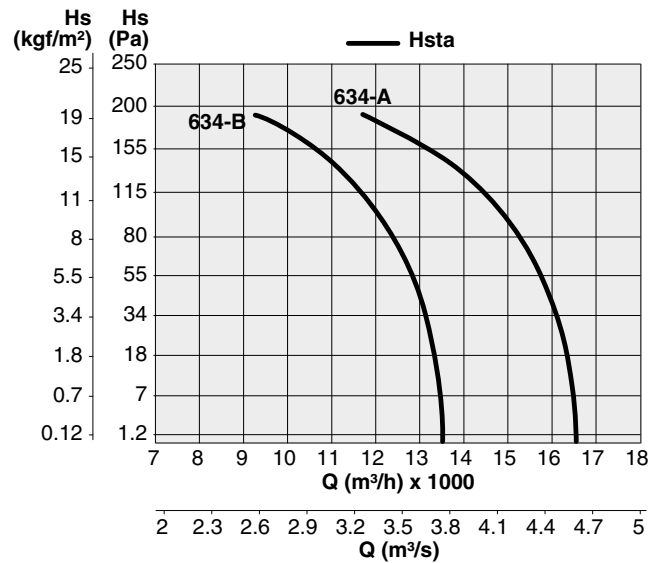

CCB 800 - 4 poli

Code	Tipo Type	Modello Model	U	P	Pm (kW)	In (A)	IP/CL	IE3	Mot. (Gr)
1CC8005		804-A	T	4	9,20	17,60	55/F	✓	132
1CC8003	CCB	804-B	T	4	7,50	14,40	55/F	✓	132
1CC8002		804-C	T	4	5,50	10,40	55/F	✓	132

LIVELLI SONORI | SOUND LEVELS dB(A)

Hz		63	125	250	500	1000	2000	4000	8000	TOT
804A	Lw	58	69	85	83	84	82	79	74	90
	Lp	40	51	67	65	66	64	61	56	73
804B	Lw	59	70	87	84	85	83	80	75	91
	Lp	41	52	69	66	67	65	62	57	74
804C	Lw	58	69	85	83	84	82	79	74	90
	Lp	40	51	67	65	66	64	61	56	73

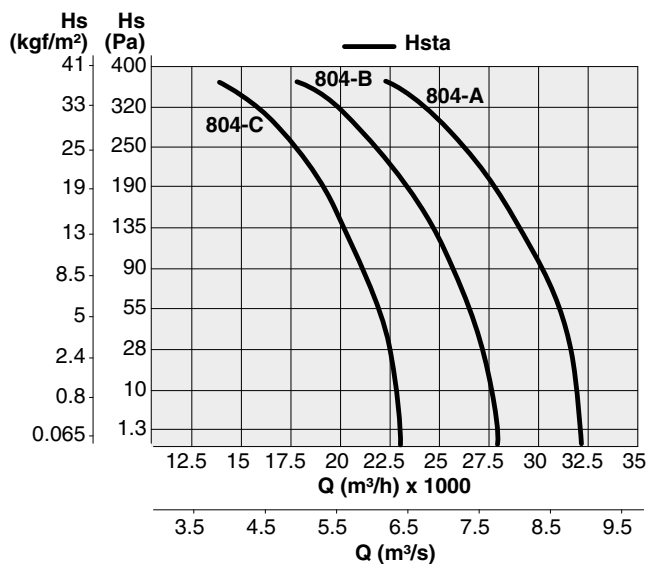

PRESTAZIONI | PERFORMANCE

CCB

CCB 1000 - 4 poli

Code	Tipo Type	Modello Model	U	P	Pm (kW)	In (A)	IP/CL	IE3	Mot. (Gr)
1CC1501		1004-A	T	4	15,00	28,30	55/F	✓	160
1CC1503	CCB	1004-B	T	4	11,00	20,90	55/F	✓	160
1CC1504		1004-C	T	4	9,20	17,60	55/F	✓	132

LIVELLI SONORI | SOUND LEVELS dB(A)

Hz		63	125	250	500	1000	2000	4000	8000	TOT
1004A	Lw	62	73	90	87	88	86	83	78	94
	Lp	44	55	72	69	70	68	65	60	77
1004B	Lw	61	72	88	86	87	85	82	77	93
	Lp	43	54	70	68	69	67	64	59	76
1004C	Lw	60	71	88	85	86	84	81	76	92
	Lp	42	53	70	67	68	66	63	58	75

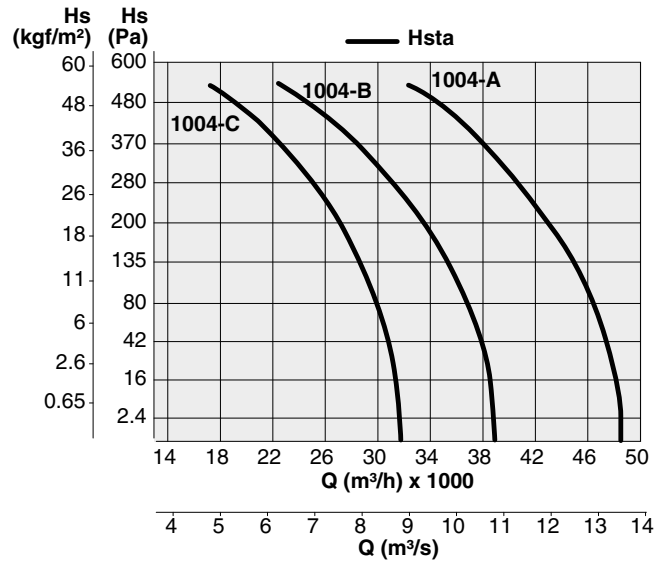

DIMENSIONI | DIMENSIONS mm

CCB

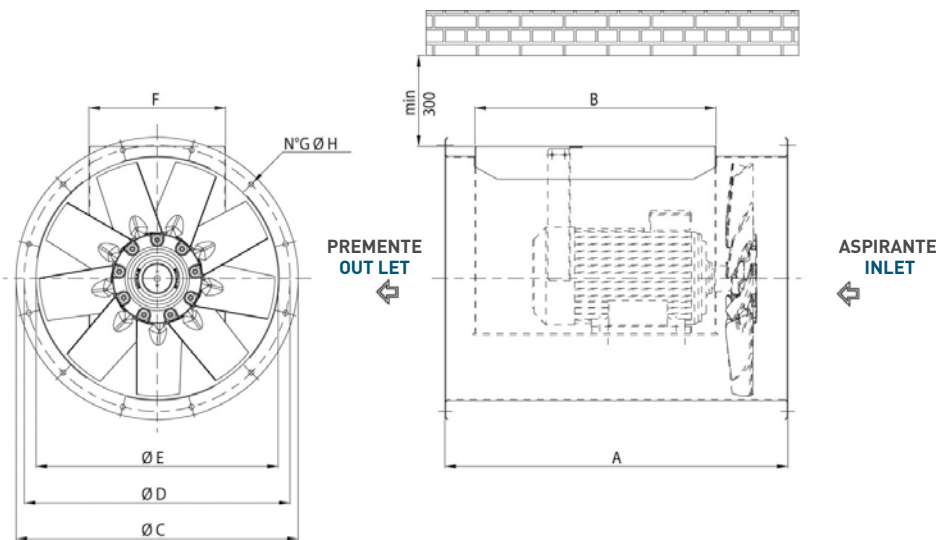

CCB

TIPO TYPE	A	B	C	D	E	F	G	H	kg
CCB 502	650	450	598	560	505	240	12	12	63
CCB 504	650	450	598	560	505	240	12	12	53
CCB 562	800	560	658	620	565	320	12	12	130
CCB 564	650	450	658	620	565	240	12	12	60
CCB 632	800	560	730	690	635	320	12	12	140
CCB 634	650	450	730	690	635	240	12	12	72
CCB 804	800	560	910	860	808	390	16	12	193
CCB 1004	1000	710	1130	1070	1010	430	16	16	303

Pesi indicativi | Indicative weights

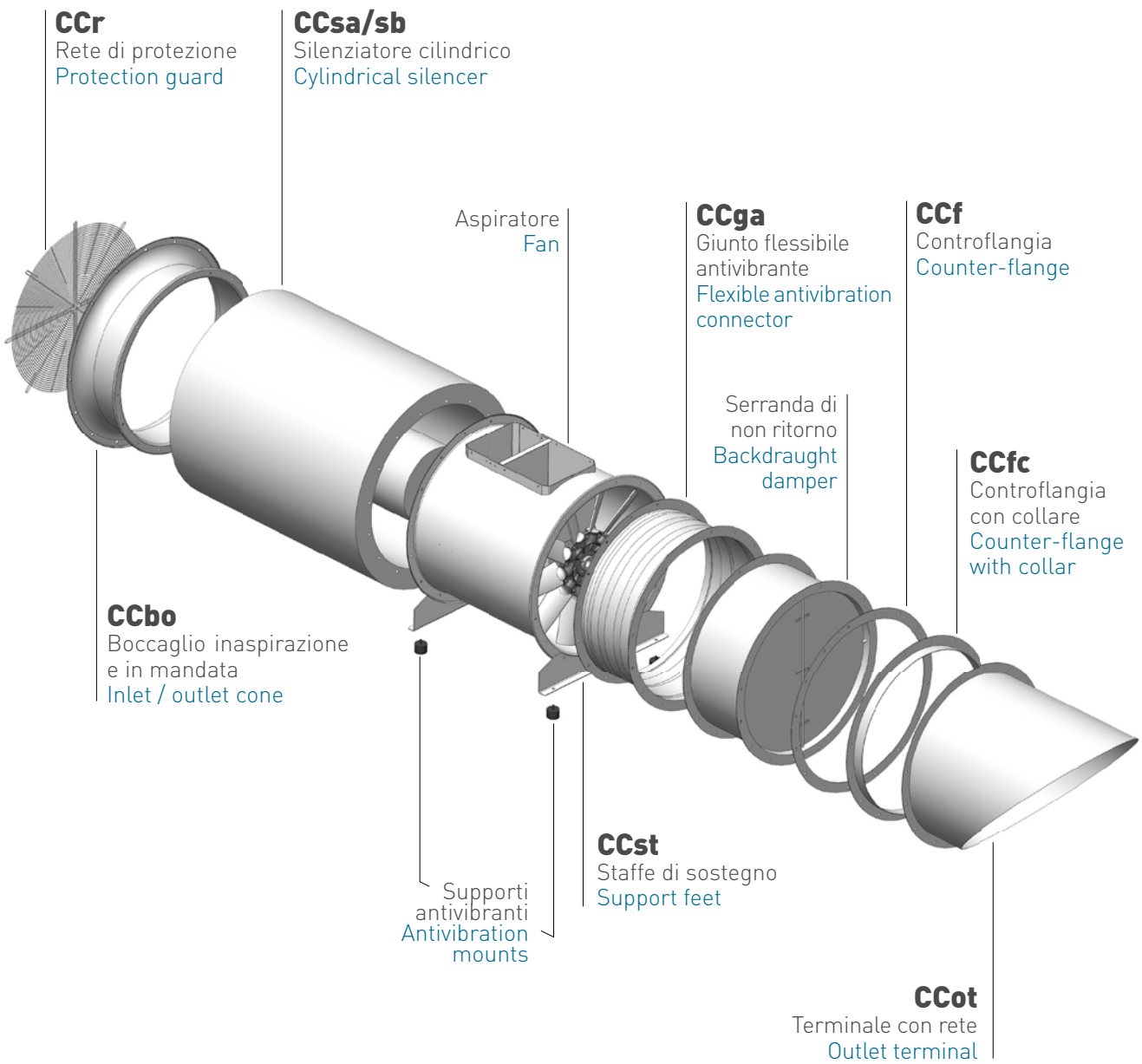



CCr | RETI PROTEZIONE | PROTECTION GUARDS

Salvaguardano dal contatto accidentale con le parti in movimento del ventilatore. Realizzate in filo d'acciaio, a norma UNI 12499 e protette contro gli agenti atmosferici.

They prevent from casual contact with moving parts of the fan. Manufactured in steel rod according to UNI 12499 standard and protected against atmospheric agents.

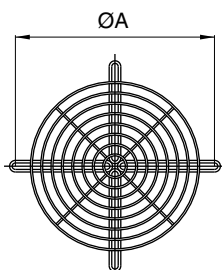

CCr

Code	Tipo Type	ØA	kg
5RE9050	CCr 50	560	1,3
5RE9056	CCr 56	620	1,6
5RE9063	CCr 63	690	1,9
5RE9071	CCr 71	770	2,2
5RE9080	CCr 80	860	3,0
5RE9090	CCr 90	970	3,4
5RE9100	CCr 100	1070	3,5

Dimensioni in mm | Dimensions in mm

SILENZIATORI CILINDRICI Cylindrical silencers

CCsa silenzianti senza ogiva | without pod

Attenuazione in dB per banda di ottava (Hz)
Octave spectrum (Hz) of noise attenuation in dB

		A= 1 x Øb							
Tipo Type		63	125	250	500	1K	2K	4K	8K
50		0	0	4	13	11	9	6	5
56		0	0	4	14	11	8	5	4
63		1	1	5	14	10	9	5	5
71		1	1	5	12	9	7	5	5
80		2	3	7	9	8	6	5	4
90		2	3	7	13	8	6	5	4
100		2	3	8	12	8	4	4	4

		A= 1,5 x Øb							
Tipo Type		63	125	250	500	1K	2K	4K	8K
50		1	1	6	18	17	12	9	7
56		1	2	7	20	15	11	8	5
63		1	2	7	20	14	12	8	6
71		2	2	7	18	11	9	6	7
80		2	5	10	13	12	9	7	7
90		2	5	11	16	11	7	7	5
100		2	5	12	17	10	6	6	5

		A= 2 x Øb							
Tipo Type		63	125	250	500	1K	2K	4K	8K
50		1	2	8	23	21	14	11	8
56		1	1	9	24	19	14	10	7
63		1	2	9	25	17	14	10	7
71		2	4	9	24	14	11	8	8
80		4	6	13	22	14	10	9	7
90		4	6	14	23	13	9	7	6
100		4	6	16	23	12	7	7	6

CCsb silenzianti con ogiva | with pod

Attenuazione in dB per banda di ottava (Hz)
Octave spectrum (Hz) of noise attenuation in dB

		A= 1 x Øb							
Tipo Type		63	125	250	500	1K	2K	4K	8K
50		1	2	5	13	20	16	11	8
56		1	1	6	15	21	17	11	8
63		1	1	6	15	19	16	10	8
71		1	2	7	15	20	18	12	10
80		2	3	9	12	17	15	9	8
90		2	4	8	15	16	11	8	7
100		4	8	14	20	24	21	14	10

		A= 1,5 x Øb							
Tipo Type		63	125	250	500	1K	2K	4K	8K
50		2	3	7	19	29	24	14	10
56		2	3	9	22	32	27	15	11
63		2	2	9	22	29	23	14	10
71		2	3	11	22	31	25	13	11
80		3	6	13	18	26	22	12	11
90		3	5	12	20	24	16	10	9
100		6	10	22	30	37	29	16	12

		A= 2 x Øb							
Tipo Type		63	125	250	500	1K	2K	4K	8K
50		2	3	10	24	38	32	18	12
56		1	2	12	27	41	35	18	12
63		2	3	11	27	37	29	15	12
71		3	5	14	29	41	32	18	15
80		3	6	16	29	35	26	15	12
90		4	7	17	30	34	20	12	11
100		7	13	28	39	47	38	19	13



CCsa | CCsb | SILENZIATORI CILINDRICI | CYLINDRICAL SILENCERS

I silenziatori cilindrici CCs sono disponibili in due versioni, senza ogiva (CCsa) e con ogiva (CCsb). La presenza dell'ogiva permette una maggiore attenuazione della rumorosità ma genera una perdita di carico aggiuntiva nell'impianto. Entrambe le versioni possono essere fissate alla flangia del CC corrispondente sia in aspirazione sia in mandata. La serie CCsa non genera perdite di carico aggiuntive. La serie CCsb, comporta una perdita di carico nella misura evidenziata nel diagramma di pagina 50. E' possibile fornire i silenziatori in versione di lunghezza pari a 1 - 1,5 - 2 volte il diametro (b). Questi silenziatori sono costruiti completamente in lamiera zincata, la parte interna e l'ogiva in lamiera forata al fine di permettere, efficacemente, l'azione del materassino fonoassorbente in lana minerale. La temperatura d'esercizio è compresa fra -40 e +150°C.

The cylindrical silencers CCs are available in two versions, without pod (CCsa) and with pod (CCsb). The presence of the pod allows a higher noise attenuation, but creates an additional pressure drop in the system. Both the versions can be fixed to the corresponding flange of the CC in inlet and outlet. The CCsa series doesn't create additional losses. The CCsb series gives an additional loss, as shown in the diagram at page 50.

Silencers can be provided with length equal to 1 - 1,5 - 2 times the diameter (b). These silencers are manufactured completely in galvanized steel. The internal part and the pod are made in perforated sheet, to effectively allow the sound absorption of the acoustic lining in mineral wool. The working temperature is included from -40°C and +150°C.

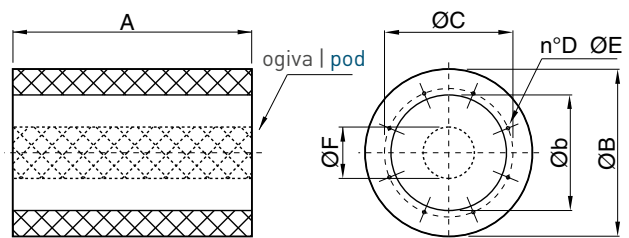

CCsa / CCsb

Tipo Type	ØB	Øb	ØC	D	ØE	ØF
50	660	500	560	12	M10	245
56	720	560	620	12	M10	295
63	790	630	690	12	M10	295
71	870	710	770	16	M10	380
80	1000	800	860	16	M10	380
90	1100	900	970	16	M12	380
100	1200	1000	1070	16	M12	650

Dimensioni in mm - Codici a richiesta
Dimensions in mm - Item code upon request

CCsa

Tipo Type	A 1Ø	kg	A 1,5Ø	kg	A 2Ø	kg
CCsa 50	500	18	750	25	1000	32
CCsa 56	560	21	840	28	1120	35
CCsa 63	630	24	945	33	1260	43
CCsa 71	710	35	1065	49	1420	63
CCsa 80	800	43	1200	61	1600	79
CCsa 90	900	70	1350	94	1800	112
CCsa 100	1000	113	1500	137	2000	161

CCsb

Tipo Type	A 1Ø	kg	A 1,5Ø	kg	A 2Ø	kg
CCsb 50	500	23	750	32	1000	39
CCsb 56	560	28	840	37	1120	44
CCsb 63	630	32	945	44	1260	55
CCsb 71	710	44	1065	62	1420	78
CCsb 80	800	56	1200	79	1600	101
CCsb 90	900	130	1350	153	1800	175
CCsb 100	1000	143	1500	180	2000	216

CCsb | DIAGRAMMA perdita di carico SILENZIATORI | SILENCER with pod loss charge DIAGRAM

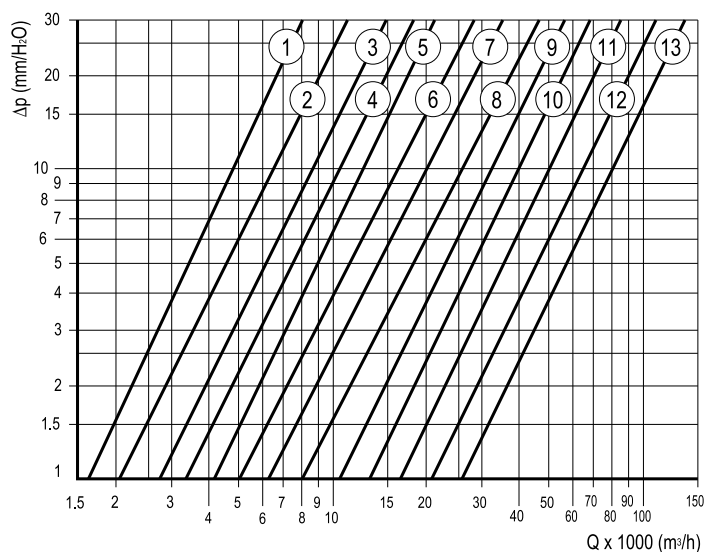

CCsb

Tipo Type	n°
CCsb 50	5
CCsb 56	6
CCsb 63	7
CCsb 71	8
CCsb 80	9
CCsb 90	10
CCsb 100	11

N.B.: Versioni senza ogiva (CCsa) hanno perdita di carico irrilevante.
Without pod (CCsa) loss charge irrelevant.



CCbo | BOCCAGLIO | INLET/OUTLET CONE

Permette un maggiore rendimento del ventilatore nel caso di bocche non canalizzate. Costruito in lamiera d'acciaio, con una flangia, realizzata a norma UNI ISO 6580 - EUROVENT, per il fissaggio al tamburo del CC e una bocca di aspirazione/diffusione ad ampio raggio con fori di fissaggio per rete CCr (di una taglia superiore, Es. CCbo 71 + CCr 80). Verniciato a polveri epossipoliestiriche.

It allows a higher fan efficiency in case of installation with inlet or outlet not ducted. Manufactured in steel sheet, with one flange according to UNI ISO6580 - EUROVENT to be fitted to the CC fan, and an aerodynamically shaped bell mouth, with fixing holes for a protection guard (of one size bigger, example CCbo 71 + CCr 80). Protected against atmospheric agents by epoxy paint.

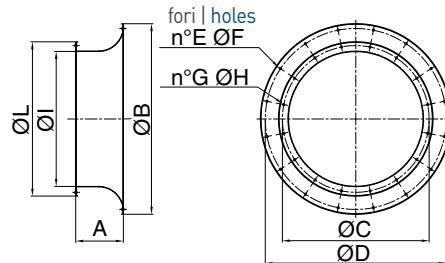

CCr di una taglia superiore of one size bigger

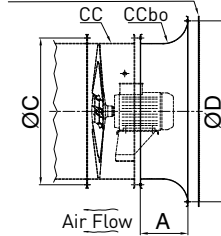

Esempi di installazione Installation example

Code	Tipo Type	A	ØB	ØC	ØD	E	ØF	G	ØH	ØI	ØL	kg
5B09650	CCbo 50	190	658	560	620	12	12	12	12	507	598	8,5
5B09656	CCbo 56	190	730	620	690	12	12	12	12	567	658	8,5
5B09663	CCbo 63	190	810	690	770	16	12	12	12	637	730	9,8
5B09671	CCbo 71	230	910	770	860	16	12	16	12	708	810	12,4
5B09680	CCbo 80	250	1025	860	970	16	16	16	12	808	910	15,2
5B09690	CCbo 90	300	1125	970	1070	16	16	16	16	910	1030	29,4
5B09700	CCbo 100	300	1245	1070	1190	20	16	16	16	1010	1130	33,3

Dimensioni in mm | Dimensions in mm

N.B.: Il flusso dell'aria potrebbe cambiare da girante a motore | Airflow direction could vary from impeller to motor.

CCga | GIUNTO ANTIVIBRANTE | FLEXIBLE CONNECTORS

Impedisce la propagazione delle vibrazioni sulla canalizzazione. Costruito con due flange in lamiera d'acciaio, realizzate a norma UNI ISO 6580 - EUROVENT per il fissaggio al ventilatore e al canale, ed un nastro di collegamento flessibile e robusto. Temperature d'utilizzo -30°C +80°C. Parti in lamiera verniciate a polveri epossipoliestiriche. Per temperature d'utilizzo diverse sono previste costruzioni speciali.

It prevents the propagation of vibrations along the ducted system. Manufactured with two flanges in steel sheet, according to UNI ISO6580 - EUROVENT standard for fixing to the fan and to the duct, and a strong flexible fabric joint. Working temperatures from -30°C to +80°C. Components in steel sheet protected against atmospheric agents by epoxy paint. Special executions are available for different working temperatures.

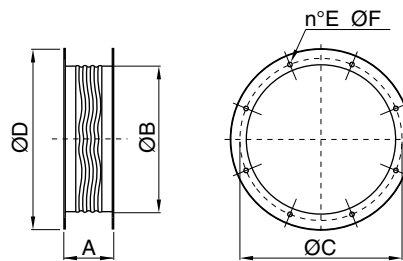

Code	Tipo Type	A	ØB	ØC	ØD	E	ØF	kg
1SU5500	CCga 50	200	505	560	598	12	12	9
1SU5560	CCga 56	200	565	620	658	12	12	10
1SU5630	CCga 63	200	635	690	730	12	12	11
1SU5710	CCga 71	200	708	770	810	16	12	13
1SU5800	CCga 80	200	808	860	910	16	12	21
1SU5900	CCga 90	200	908	970	1030	16	16	23
1SU6000	CCga 100	200	1010	1070	1130	16	16	26

Dimensioni in mm | Dimensions in mm



CCst | STAFFE DI SOSTEGNO | SUPPORT FEET

Consentono l'ancoraggio del ventilatore a pavimento o soffitto. Realizzate in lamiera d'acciaio e verniciate a polveri epossipoliestiriche. Fornite a coppia.

Suitable to fasten the fan on the floor or to the ceiling. Manufactured in steel sheet and protected against atmospheric agents by epoxy paint. Supplied in sets of 2.

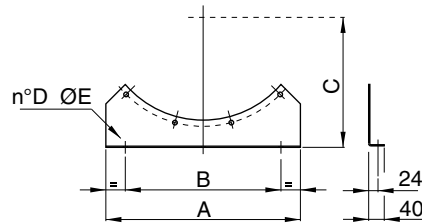

Code*	Tipo Type	A	B	C	D	ØE	kg**
1ST0500	CCst 50	500	400	380	2	10	2,1
1ST0560	CCst 56	560	460	410	2	10	2,5
1ST0630	CCst 63	630	480	450	2	10	2,8
1ST0710	CCst 71	710	550	490	2	10	3,1
1ST0800	CCst 80	800	660	540	3	14	3,7
1ST0900	CCst 90	900	760	600	3	14	4,5
1ST1000	CCst 100	1000	860	640	3	14	4,8

Dimensioni in mm - * Codice della coppia - ** Peso di una staffa
Dimensions in mm - *Item code of the set of 2 - **Weight of a single support

CCf | CONTROFLANGIA | COUNTER FLANGE

Piastra a forma di anello provvista di fori a norma UNI ISO 6580 - EUROVENT. Viene utilizzata per facilitare il collegamento tra il canale ed il ventilatore.

Ring plate with holes according to UNI ISO6580 - EUROVENT standard, compatible with fan flange. It is used for easier connection between the CC fan and the duct.

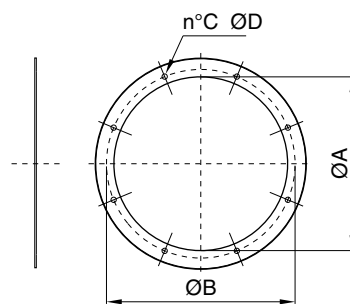

Code	Tipo Type	ØA	ØB	C	ØD	kg
5B01050	CCf 50	500	560	12	12	2,1
5B01056	CCf 56	560	620	12	12	2,4
5B01063	CCf 63	630	690	12	12	2,7
5B01071	CCf 71	710	770	16	12	3,3
5B01081	CCf 80	800	860	16	12	3,7
5B01092	CCf 90	900	970	16	16	4,7
5B01110	CCf 100	1000	1070	16	16	5,2

Dimensioni in mm | Dimensions in mm

CCfc | GIUNTO ANTIVIBRANTE | FLEXIBLE CONNECTORS

Controflangia a forma di anello con collare, provvista di fori a norma UNI ISO 6580 - EUROVENT. Viene utilizzata per facilitare il collegamento tra il canale ed il ventilatore.

Counter flange with addition of 80 mm of round duct. It is used for easier connection between the CC fan and the duct.

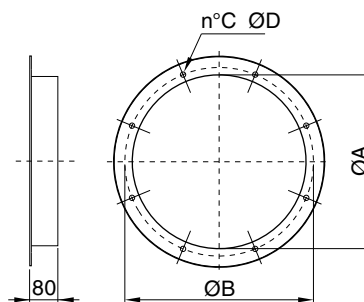

Code	Tipo Type	ØA	ØB	C	ØD	kg
5B01550	CCfc 50	505	560	12	12	2,2
5B01556	CCfc 56	565	620	12	12	2,5
5B01563	CCfc 63	635	690	12	12	2,9
5B01571	CCfc 71	710	770	16	12	3,3
5B01580	CCfc 80	808	860	16	12	3,8
5B01590	CCfc 90	908	970	16	16	4,2
5B01600	CCfc 100	1010	1070	16	16	5

Dimensioni in mm | Dimensions in mm

CCot | TERMINALE CON RETE | OUTLET TERMINAL

Terminale parapigioggia con rete di protezione.
Outlet terminal with protection guard.

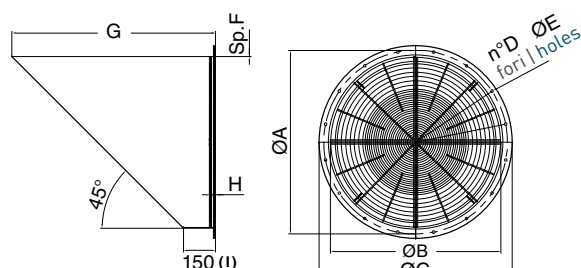

(I) 200 mm da | from CCot 100 a | to 160

Code	Tipo Type	ØA	ØB	ØC	D	ØE	F	G	H	kg
5TR0502	CCot 50	560	500	603	12	12	20/10	655	20	12,5
5TR0503	CCot 56	620	560	663	12	12	20/10	710	20	15
5TR0504	CCot 63	690	630	733	12	12	20/10	785	20	18
5TR0505	CCot 71	770	710	813	16	12	20/10	865	25	22,5
5TR0506	CCot 80	860	800	903	16	12	30/10	950	25	39
5TR0507	CCot 90	970	900	1013	16	16	30/10	1050	25	48
5TR0508	CCot 100	1070	1000	1113	16	16	40/10	1200	30	80

Dimensioni in mm | Dimensions in mm